

# Contents

## HP E1586A Rack Mount Terminal Panel User's Manual

---

Description .....	5
Connecting to VXIbus Instruments .....	5
Interconnect Cables .....	5
Terminal Block Connections .....	6
Using the Terminal Panel for Reference Temperature Measurements .....	7
Mounting the HP E1586 Terminal Panel .....	7
Reference Thermistor Connections and Operations .....	7
Using the Option 001 RF Filter .....	9
Analog Inputs Using Three-wire Cabling .....	9
Analog Inputs Using Two-Wire Cabling .....	10
Configuration for HP E1413/E1415 with Digital I/O SCPs .....	11
Typical Reference Temperature Measurements .....	12
Measuring Using the Center Thermistor .....	13
Measuring Using the Left, Center, and Right Thermistors .....	14



---

## Certification

*Hewlett-Packard Company certifies that this product met its published specifications at the time of shipment from the factory. Hewlett-Packard further certifies that its calibration measurements are traceable to the United States National Institute of Standards and Technology (formerly National Bureau of Standards), to the extent allowed by that organization's calibration facility, and to the calibration facilities of other International Standards Organization members.*

---

## Warranty

This Hewlett-Packard product is warranted against defects in materials and workmanship for a period of three years from date of shipment. Duration and conditions of warranty for this product may be superseded when the product is integrated into (becomes a part of) other HP products. During the warranty period, Hewlett-Packard Company will, at its option, either repair or replace products which prove to be defective.

For warranty service or repair, this product must be returned to a service facility designated by Hewlett-Packard (HP). Buyer shall prepay shipping charges to HP and HP shall pay shipping charges to return the product to Buyer. However, Buyer shall pay all shipping charges, duties, and taxes for products returned to HP from another country.

HP warrants that its software and firmware designated by HP for use with a product will execute its programming instructions when properly installed on that product. HP does not warrant that the operation of the product, or software, or firmware will be uninterrupted or error free.

## Limitation Of Warranty

The foregoing warranty shall not apply to defects resulting from improper or inadequate maintenance by Buyer, Buyer-supplied products or interfacing, unauthorized modification or misuse, operation outside of the environmental specifications for the product, or improper site preparation or maintenance.

The design and implementation of any circuit on this product is the sole responsibility of the Buyer. HP does not warrant the Buyer's circuitry or malfunctions of HP products that result from the Buyer's circuitry. In addition, HP does not warrant any damage that occurs as a result of the Buyer's circuit or any defects that result from Buyer-supplied products.

**NO OTHER WARRANTY IS EXPRESSED OR IMPLIED. HP SPECIFICALLY DISCLAIMS THE IMPLIED WARRANTIES OF MERCHANTABILITY AND FITNESS FOR A PARTICULAR PURPOSE.**

## Exclusive Remedies

**THE REMEDIES PROVIDED HEREIN ARE BUYER'S SOLE AND EXCLUSIVE REMEDIES. HP SHALL NOT BE LIABLE FOR ANY DIRECT, INDIRECT, SPECIAL, INCIDENTAL, OR CONSEQUENTIAL DAMAGES, WHETHER BASED ON CONTRACT, TORT, OR ANY OTHER LEGAL THEORY.**

---

## Notice

The information contained in this document is subject to change without notice. HEWLETT-PACKARD (HP) MAKES NO WARRANTY OF ANY KIND WITH REGARD TO THIS MATERIAL, INCLUDING, BUT NOT LIMITED TO, THE IMPLIED WARRANTIES OF MERCHANTABILITY AND FITNESS FOR A PARTICULAR PURPOSE. HP shall not be liable for errors contained herein or for incidental or consequential damages in connection with the furnishing, performance or use of this material. This document contains proprietary information which is protected by copyright. All rights are reserved. No part of this document may be photocopied, reproduced, or translated to another language without the prior written consent of Hewlett-Packard Company. HP assumes no responsibility for the use or reliability of its software on equipment that is not furnished by HP.

---



HP E1586A Rack Mount Terminal Panel Installation and User's Manual  
Edition 1  
Copyright © 1996 Hewlett-Packard Company. All Rights Reserved.

---

## Documentation History

All Editions and Updates of this manual and their creation date are listed below. The first Edition of the manual is Edition 1. The Edition number increments by 1 whenever the manual is revised. Updates, which are issued between Editions, contain replacement pages to correct or add additional information to the current Edition of the manual. Whenever a new Edition is created, it will contain all of the Update information for the previous Edition. Each new Edition or Update also includes a revised copy of this documentation history page.

Edition 1 ..... May 1996

---

## Safety Symbols



Instruction manual symbol affixed to product. Indicates that the user must refer to the manual for specific WARNING or CAUTION information to avoid personal injury or damage to the product.



Indicates the field wiring terminal that must be connected to earth ground before operating the equipment. Protects against electrical shock in case of fault.

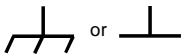

Frame or chassis ground terminal—typically connects to the equipment's metal frame.



Alternating current (AC)



Direct current (DC).



Indicates hazardous voltages.

**WARNING**

Calls attention to a procedure, practice, or condition that could cause bodily injury or death.

**CAUTION**

Calls attention to a procedure, practice, or condition that could possibly cause damage to equipment or permanent loss of data.

---

## WARNINGS

The following general safety precautions must be observed during all phases of operation, service, and repair of this product. Failure to comply with these precautions or with specific warnings elsewhere in this manual violates safety standards of design, manufacture, and intended use of the product. Hewlett-Packard Company assumes no liability for the customer's failure to comply with these requirements.

**Ground the equipment:** For Safety Class 1 equipment (equipment having a protective earth terminal), an uninterruptible safety earth ground must be provided from the mains power source to the product input wiring terminals or supplied power cable.

DO NOT operate the product in an explosive atmosphere or in the presence of flammable gases or fumes.

For continued protection against fire, replace the line fuse(s) only with fuse(s) of the same voltage and current rating and type. DO NOT use repaired fuses or short-circuited fuse holders.

**Keep away from live circuits:** Operating personnel must not remove equipment covers or shields. Procedures involving the removal of covers or shields are for use by service-trained personnel only. Under certain conditions, dangerous voltages may exist even with the equipment switched off. To avoid dangerous electrical shock, DO NOT perform procedures involving cover or shield removal unless you are qualified to do so.

**DO NOT operate damaged equipment:** Whenever it is possible that the safety protection features built into this product have been impaired, either through physical damage, excessive moisture, or any other reason, REMOVE POWER and do not use the product until safe operation can be verified by service-trained personnel. If necessary, return the product to a Hewlett-Packard Sales and Service Office for service and repair to ensure that safety features are maintained.

**DO NOT service or adjust alone:** Do not attempt internal service or adjustment unless another person, capable of rendering first aid and resuscitation, is present.

**DO NOT substitute parts or modify equipment:** Because of the danger of introducing additional hazards, do not install substitute parts or perform any unauthorized modification to the product. Return the product to a Hewlett-Packard Sales and Service Office for service and repair to ensure that safety features are maintained.

# HP E1586A Rack Mount Terminal Panel

---

## Description

The HP E1586 Rack Mount Terminal Panel provides extended connections to certain VXIbus instruments, like the HP E1413C High Speed A/D Converter, HP E1415A Algorithmic Closed Loop Controller, and HP E1476A 64-Channel T/C and Low Offset Relay Multiplexer. The Terminal Panel is recommended if the VXIbus instruments are located a distance away from the measurement connections. The Terminal Panel provides up to 32 3-wire connections to allow for 32 channel connections to the VXIbus instruments.

Since the Terminal panel only provides 32 channels, use an additional HP E1586 Terminal Panel when using it with an HP E1413C, E1415A, or E1476A.

The Terminal Panel also provides three on-board thermistors for sensing the isothermal reference temperature of the Terminal Panel. The three thermistors provide substantial accuracy improvements when temperature gradients are generated across the length of the Terminal Panel.

The HP E1586 Terminal Panel can be ordered with optional High Frequency Common Mode Filters (i.e., HP E1586 Option 001, RF Filters). These filters are connected to the input terminal and are used to filter out AC common mode signals present in the cables that connect between the terminal panel and the device under test. The filters are useful for filtering out small common mode signals below 5 Vp-p. To order these filters, order HP E1586 Option 001.

## Connecting to VXIbus Instruments

Figure 1 on page 6 shows how to connect the Terminal Panel to a VXIbus instrument. The connections are made to an HP E1413C Option A3F Terminal Module.

## Interconnect Cables

The panel uses SCSI cables to make the connections to the VXIbus modules. Note that the modules must have the correct Terminal Modules (e.g., HP E1413C/E1415A Opt A3F) installed to make these connections. Each cable provides connections for 16-channels thus each Terminal Panel requires two cables to make 32-channel connections.

The cables do not come with the Terminal Panel and must be ordered separately. The available cables described in the following.

### Standard Cable

This cable (HP E1588A) is a 16-channel twisted pair cable with an outer shield. This cable is suitable for relatively short cable runs.

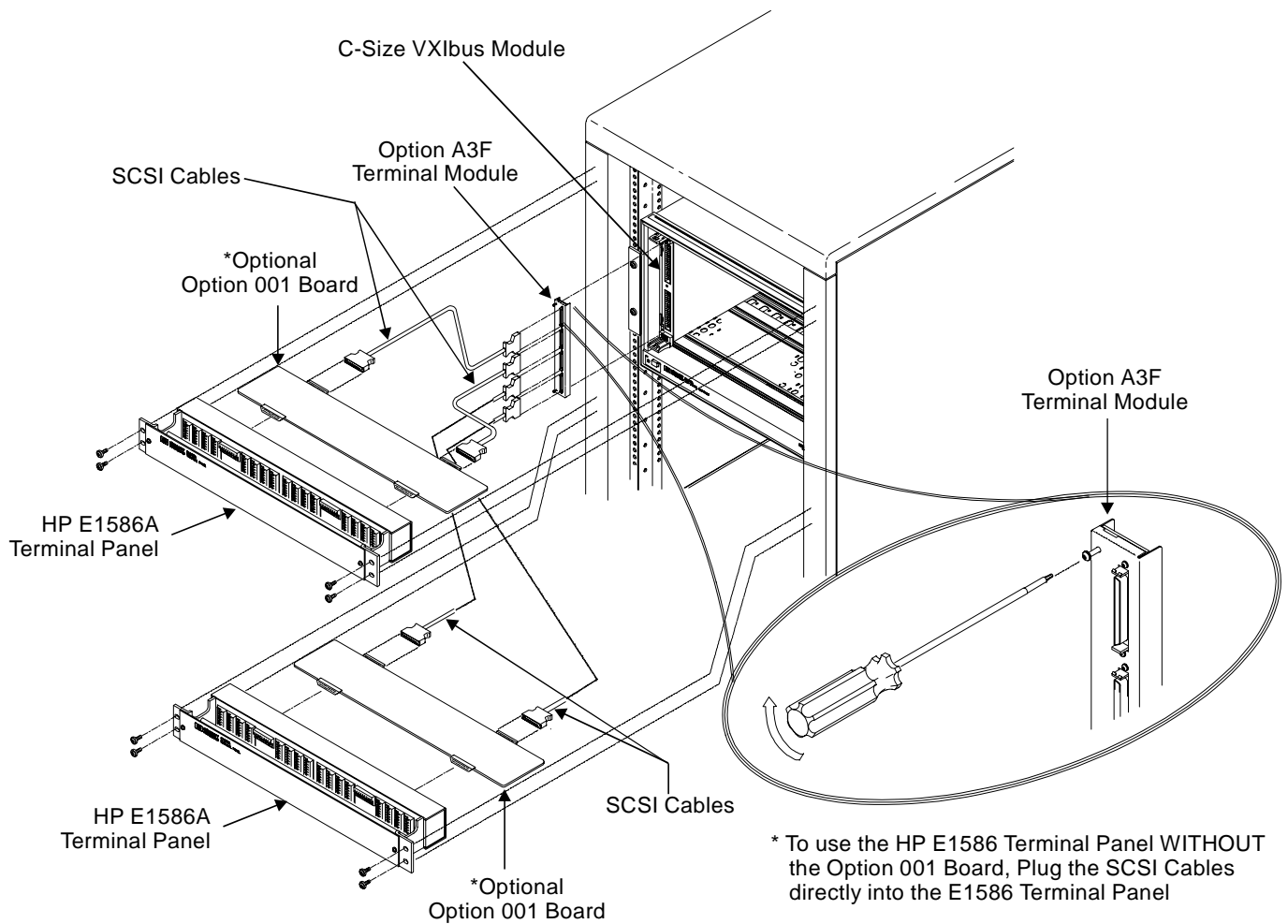

**Figure 1. Connecting the Terminal Panel**

**Custom Length Cable**

This cable (HP Z2220A Option 050) is available in custom lengths. It is a 16-channel twisted pair cable with each twisted pair individually shielded to provide better quality shielding for longer cable runs.

## Terminal Block Connections

Figure 2 on page 7 shows typical connections to the Terminal Panel. The panel provides four terminal blocks for the connections. These blocks consist of eight three-wire sets of terminals with each terminal set marked HI, LO, and G. The HI marking is for High connection, LO is for Low connections, and G is for Guard connections.

Each terminal set also includes channel numbers, like 0(32), 4(36), etc., where the numbers outside the parenthesis indicate channels 00-31, and the numbers inside the parenthesis indicate channels 32-63. These numbers, and the HI, LO, and G terminals, correspond directly to the channel numbers and input terminals of the HP E1413C and E1415A.

# Using the Terminal Panel for Reference Temperature Measurements

The following explains how to use the Terminal Panel as an isothermal reference panel for thermocouple measurements. This explanation is for connections to an HP E1413C High Speed A/D Converter or an HP E1415A Algorithmic Closed Loop Controller

## Mounting the HP E1586 Terminal Panel

The Terminal Panel can be mounted in a standard size instrument rack. To minimize temperature gradients across the panel, it should be mounted in the rack such that it is away from the other heat sources. The bottom of the rack is usually the preferred location. Take particular care to minimize the temperature differences across the horizontal width of the Terminal Panel, since it is most susceptible to horizontal temperature gradients across its longest dimension.

## Reference Thermistor Connections and Operations

The HP E1586 Terminal Panel's three thermistors are located next to the channel 3 terminal block, between channels 11 and 16, and next to channel 24 (see Figure 2 on page 7).

## Thermistor Excitation Sources

Both an HP E1413C or E1415A provides a 122uA current source as the excitation for the thermistors. This is available on the Terminal Panel's terminals labeled HI-I and LO-I. For other modules, use an external Voltmeter or Multimeter like the HP E1411 or E1412.

The excitation current is ONLY available to the Terminal panel connected to channels 00-31 of the HP E1413C/E1415A. This current is NOT on the Terminal Panel connected to channels 32-63 of the HP E1413C/E1415A.

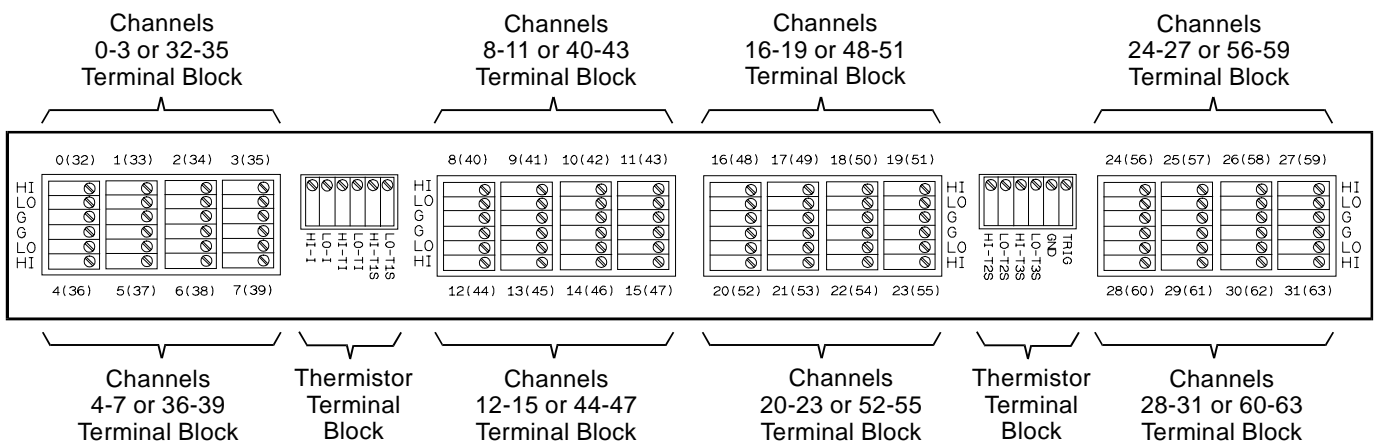

Figure 2. Terminal Panel Connections

The following shows how to connect the thermistors to the HP E1413C/ E1415A current source. For the Terminal Panel's on-board thermistors excitation, connect HI-I to HI-TI, and LO-I to LO-TI, respectively.

### Connecting One Terminal Panel for Reference Temperature Measurements

In this configuration, a single Terminal Panel is used with an HP E1413C/ E1415A to provide up to 32 channels for temperature measurements. Make the following connections on the thermistor terminal block of the Terminal Panel: Connect HI-I to HI-TI Connect LO-I to LO-TI

This provides the excitation current to all three on-board thermistors on the Terminal Panel. Figure 3 on page 8 shows the connection for a single Terminal Panel

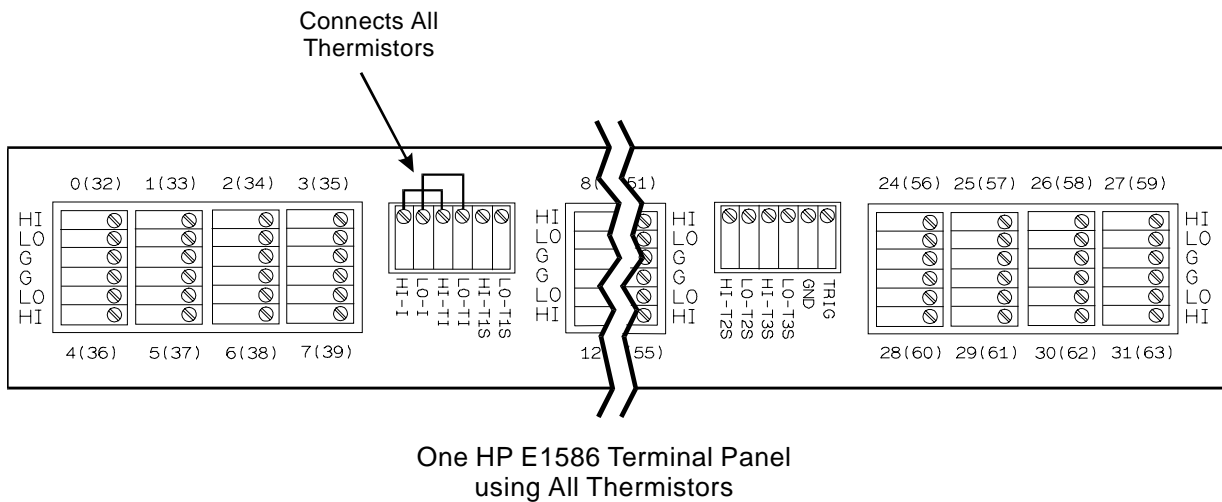

Figure 3. Connecting Three Thermistors on a Single Panel

### Connecting Two Terminal Panels for Reference Temperature Measurements

In this configuration, two Terminal Panels are used with an HP E1413C/ E1415A to provide up to 64 channels for temperature measurements. Make the following connections on the thermistor terminal blocks of both Terminal Panels:

Connect HI-I to HI-TI of the First Terminal panel  
 Connect LO-I to LO-TI of the First Terminal Panel  
 Connect LO-TI of the First Terminal Panel to HI-TI of the Second Terminal Panel  
 Connect LO-TI of the Second Terminal Panel to LO-I of the First Terminal Panel.

This provides the excitation current to all six on-board thermistors on the Terminal Panels. Figure 4 on page 9 shows the connection for two Terminal Panels.



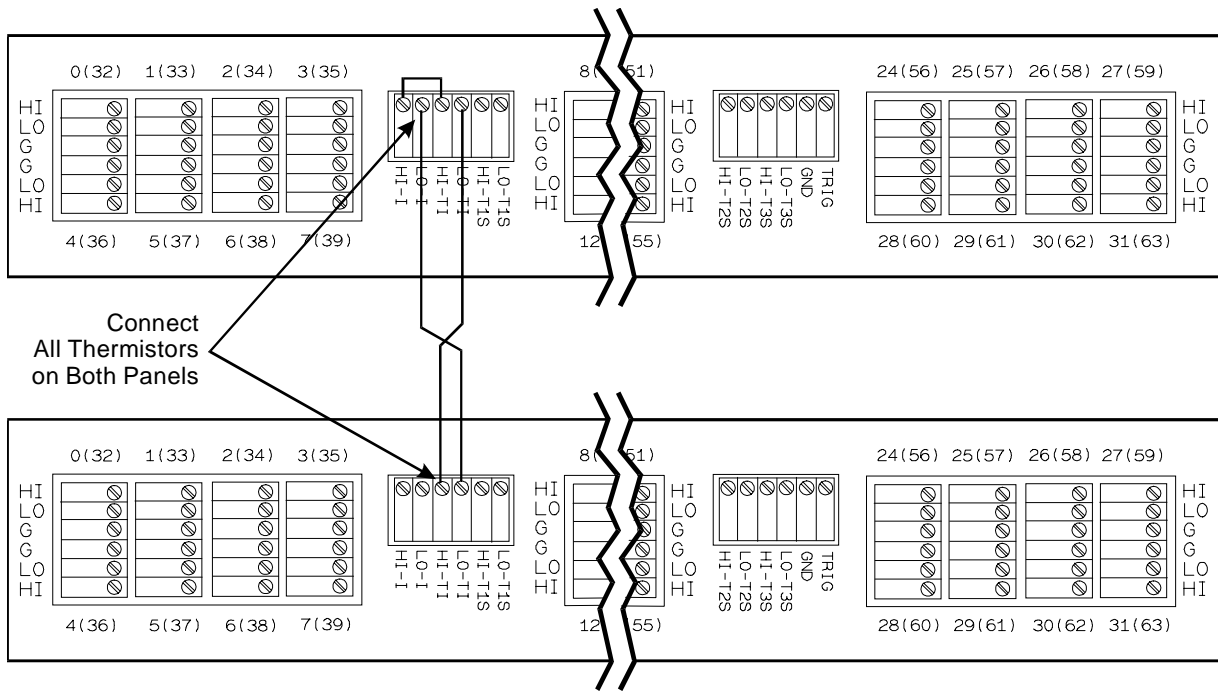

Two HP E1586 Terminal Panels  
using All Thermistors on Each Panel

Figure 4. Connecting Six Thermistors on Two Panels

## Using the Option 001 RF Filter

The HP E1586 Option 001 Terminal Panel has an additional board that contains the RF Filters. These filters consist of a 3-winding common-mode transformers for each channel. These transformers greatly attenuate common mode signals above 1 kHz. In combination with a properly connected Option 001 Terminal Panel, the HP E1413C/E1415A can achieve common mode rejection ratios of >100 dB for signals from DC to >10 Mhz.

These transformers do not limit the measurement bandwidth of the HP E1413C/E1415A. The RF Filter Board, using on board jumpers, can be configured for various wiring and Signal Conditioning Plug-on (SCP) combinations for the HP E1413/E1415.

### Analog Inputs Using Three-wire Cabling

In this configuration, the HI, LO, and shield terminals are used for each channel. This is the preferred wiring for configuration of low level analog channels and provides the best common-mode rejection performance. To configure the Terminal Panel, move the jumpers for each channel as shown in Figure 5 on page 10.

The configuration in the figure removes the RC-filters from the path and enables the common-mode transformers. Be sure the side by jumpers are moved into the same position, or poor Common Mode Rejection will result.

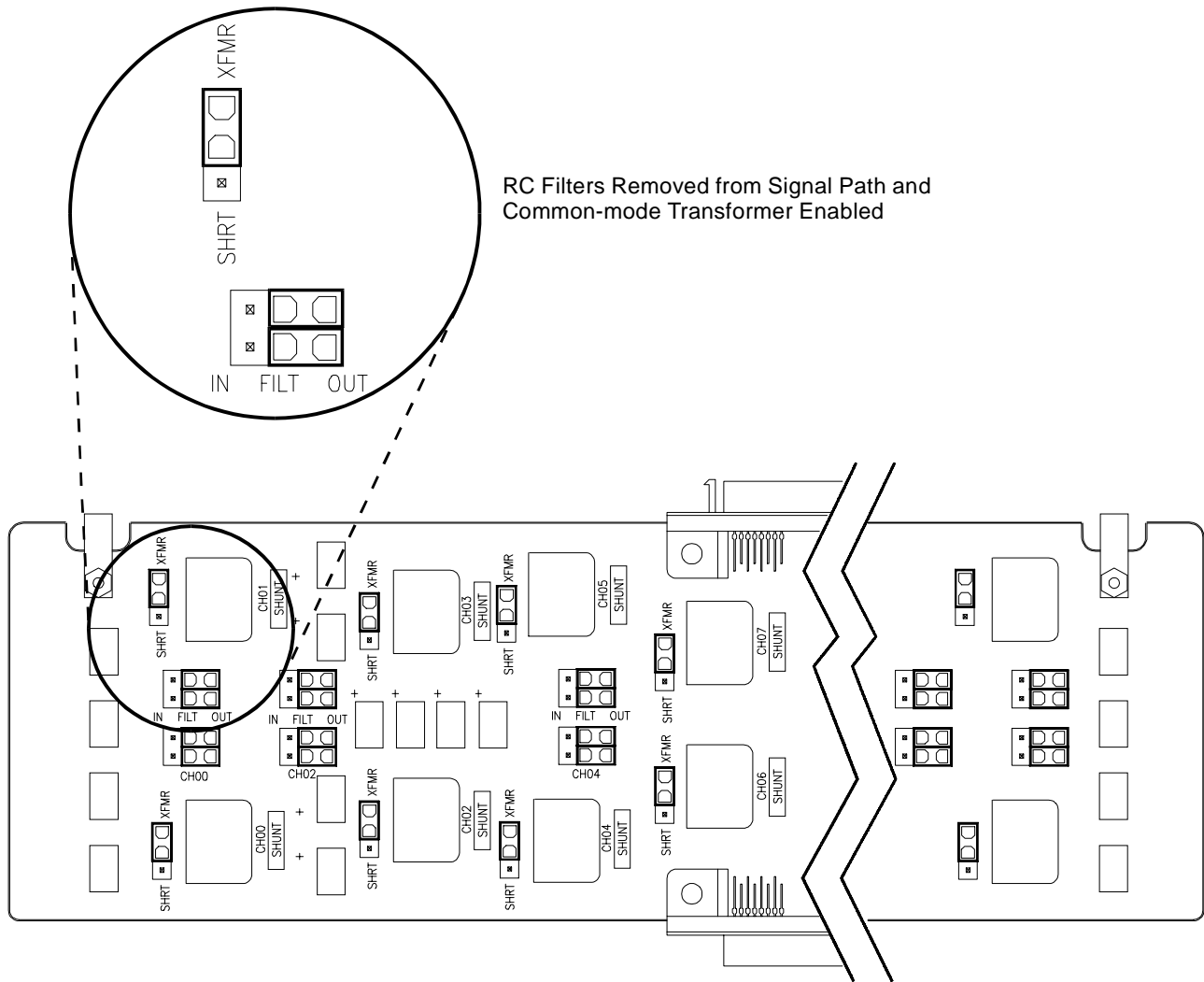

**Figure 5. Option 001 Three-Wire Cable Configuration**

## Analog Inputs Using Two-Wire Cabling

In this configuration, the HI and LO terminals are used for each channel, without the shield terminal being used. This is not the preferred wiring for low noise rejection, but may be necessary for certain configurations. For example, some isolation Signal Conditioning Plug-ons used by the E1413 or E1415, such as the E1514, E1515, E1516, and E1517, must use this configuration. This is because those SCPs have no shield connections available. To configure the Terminal Panel, move the jumpers for each channel as shown in Figure 6 on page 11.

Since there is no shield available to drive the third winding of the common-mode transformer, the transformer effectiveness is reduced. To provide additional high frequency filtering, RC filters are provided on the board.

Use of the filters decreases the low-frequency Common-mode Rejection to about 90 dB at 60 Hz, and the measurement bandwidth to about 10 kHz for the E1413 or E1415.

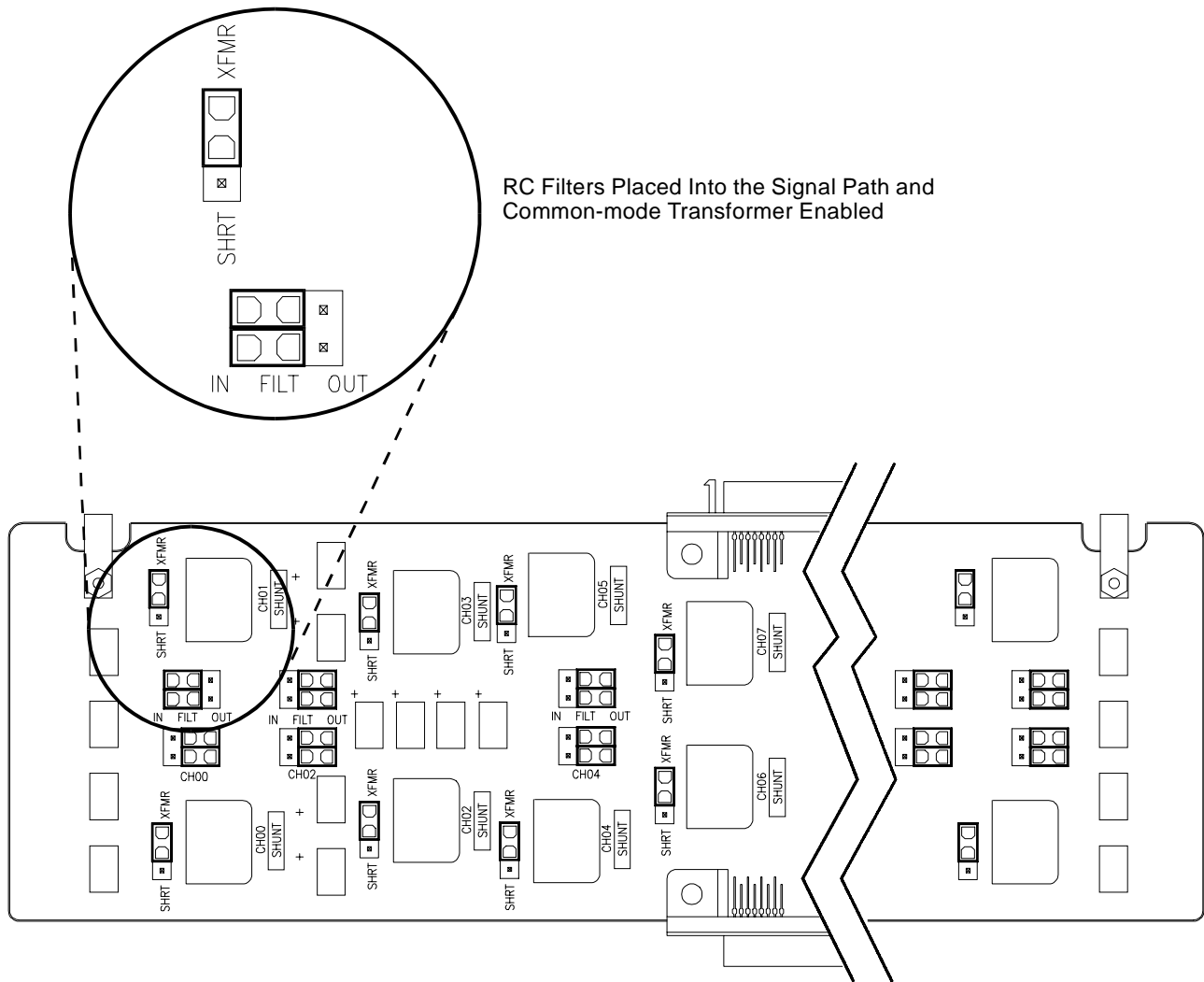

Figure 6. Option 001 Two-Wire Cable Configuration

### Configuration for HP E1413/E1415 with Digital I/O SCPs

This configuration should be used for the HP E1413/E1415 Digital I/O Signal Conditioning Plug-on (SCP). This especially the case when low level analog SCPs are used with the digital I/O SCP. This configuration may make it necessary to connect the digital channels through the E1586 Option 001 board. To configure the Terminal Panel, when using a digital I/O SCP, move the jumpers for each affected channel as shown in Figure 7 on page 12

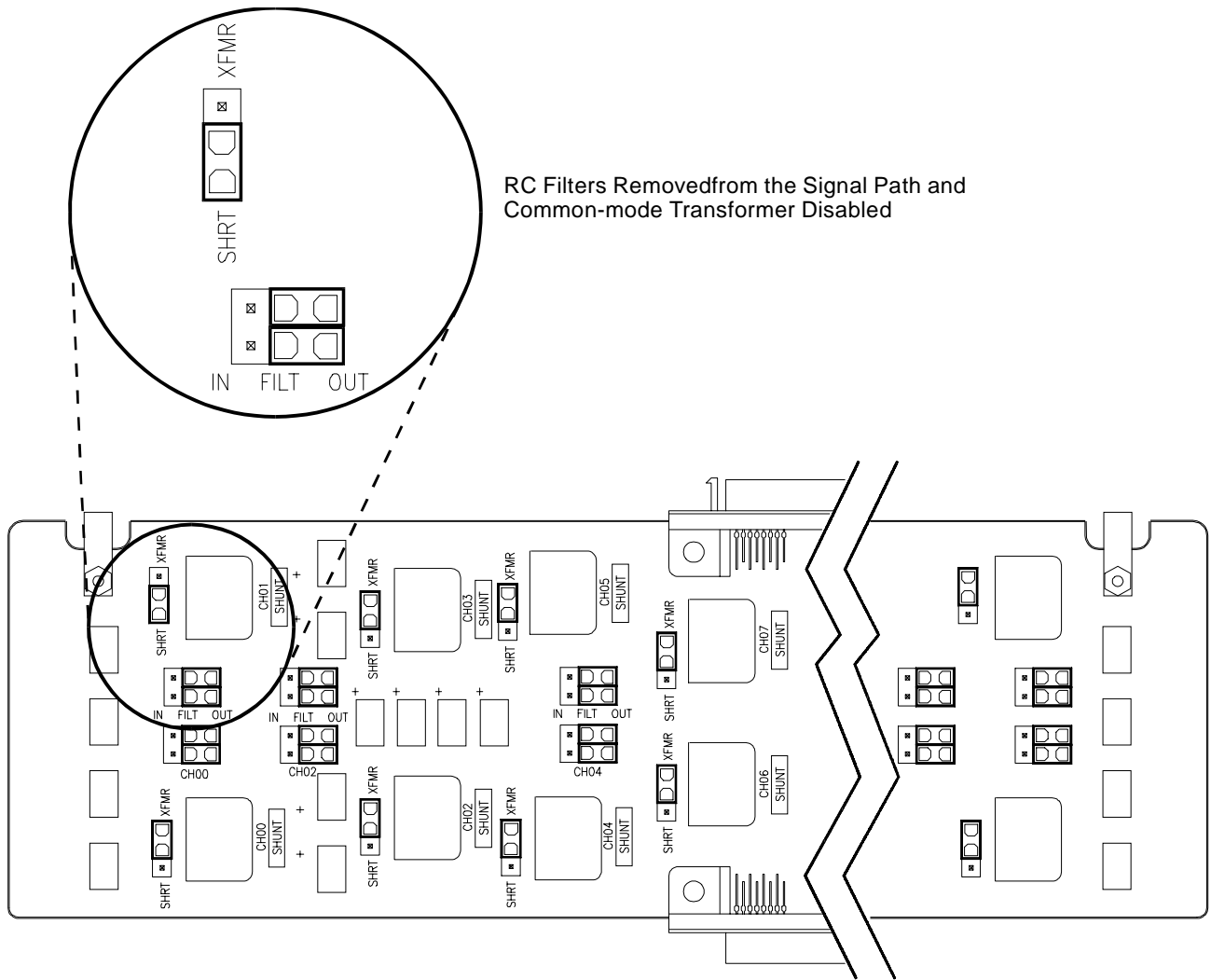

Figure 7. Option 001 Digital I/O SCP Configuration

## Typical Reference Temperature Measurements

The following shows how to make reference temperature measurements on the E1586 thermistors using the HP E1413 High Speed A/D Converter or the HP E1415A Algorithmic Closed Loop Controller.

The methods to measure the thermistor reference temperature depends on the location of the Terminal Panel. For Terminal Panels mounted away from heat sources, it is only necessary to measure the center thermistor. Use the information in "Measuring Using the Center Thermistor".

For Terminal Panels mounted in such a way that temperature gradients are generated along its length, measure all three thermistors. Use the information in "Measuring Using the Left, Center, and Right Thermistors".

## Measuring Using the Center Thermistor

To measure the center thermistor, select an HP E1413C or E1415A channel as a reference channel. Connect the reference channel's HI and LO to the center thermistor (thermistor 2) HI-T2S and LO-T2S terminals, respectively. These connections are shown in Figure 8 on page 13.

If two Terminal Panels are used, each panel must be connected as above so that both panels provide reference temperature measurements. These connections are shown in Figure 9 on page 14.

Use the information in the HP E1414C/E1415A User's manuals to setup the instruments to make the reference measurements. The following is an example that uses two Terminal Panels to measure type K thermocouples.

```
SENS:REF THER,5000,1,(@100,132)
    measures reference temperature measurements on channels 100 and 132
SENS:FUNC:TEMP TC,K,.06,(@101:131,133:163)
    defines channels for temperature measurements
ROUT:SEQ:DEF (@100,101:131,132,133:163)
    defines the scan list.
```

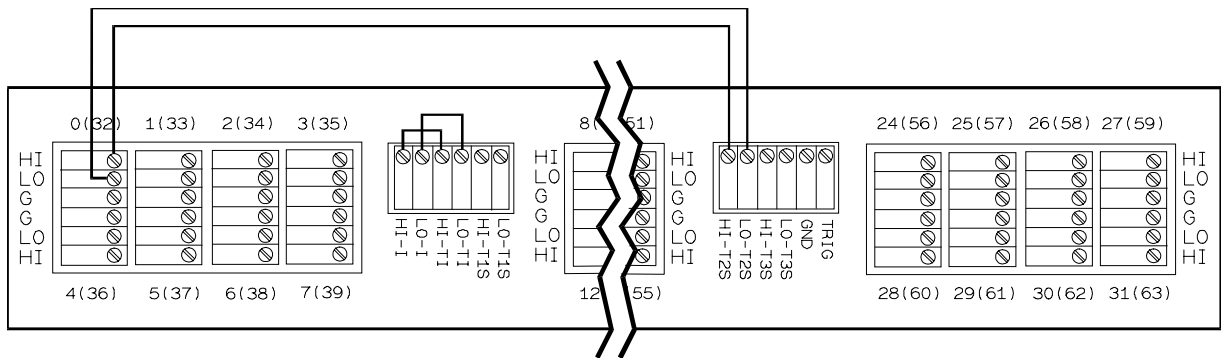

One HP E1586 Terminal Panel  
Measuring One Thermistor  
on Reference Channel 100

**Figure 8. Center Thermistor Measurements on a Single Panel**

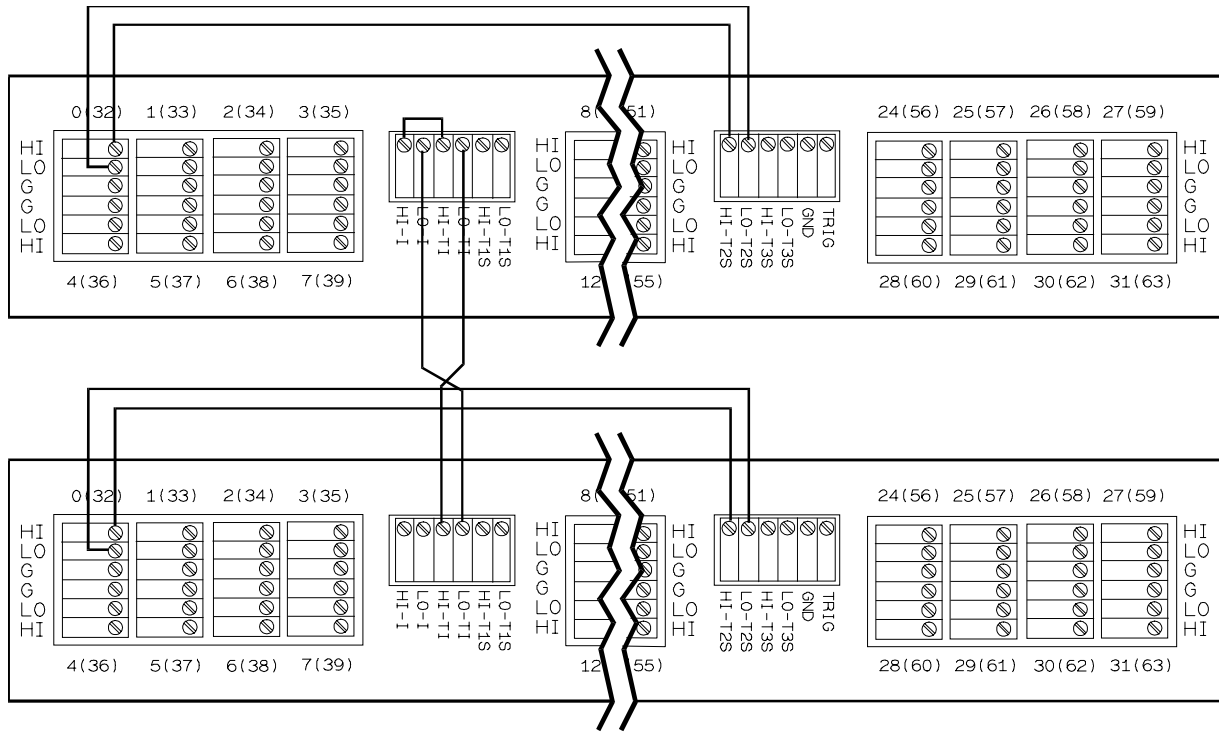

Two HP E1586 Terminal Panels  
Measuring One Thermistor on Each Panel  
on Reference Channels 100, 132

Figure 9. Center Thermistor Measurements on Multiple Panels

### Measuring Using the Left, Center, and Right Thermistors

To measure all three thermistors, select three HP E1413C/E1415A channels as reference channels. The recommended method is to use thermistor 1, the left thermistor (HI-T1S and LO-T1S), as a reference for channels 0 - 7 (or 32 - 39), thermistor 2, the center thermistor (HI-T2S and LO-T2S), for channels 8 - 23 (or 40 - 47), and thermistor 3, the right thermistor (HI-T3S and LO-T3S), for channels 24 - 31 (or 56 - 63). Connect the reference channels HI and LO terminals to the respective

Connect the reference channel's HI and LO terminals to the appropriate thermistor terminals (e.g., channel 100 HI and LO terminals to thermistor 1 HI-T1S and LO-T1S terminals, respectively). These connections are shown in Figure 10 on page 15.

If two Terminal Panels are used, each panel must be connected as above so that both panels provide reference temperature measurements. These connections are shown in Figure 11 on page 16.

Use the information in the HP E1414C/E1415A User's manuals to setup the instruments to make the reference measurements. The following are two examples that measure type K thermocouples. One example uses a single Terminal Panel and the other uses two Terminal Panels.

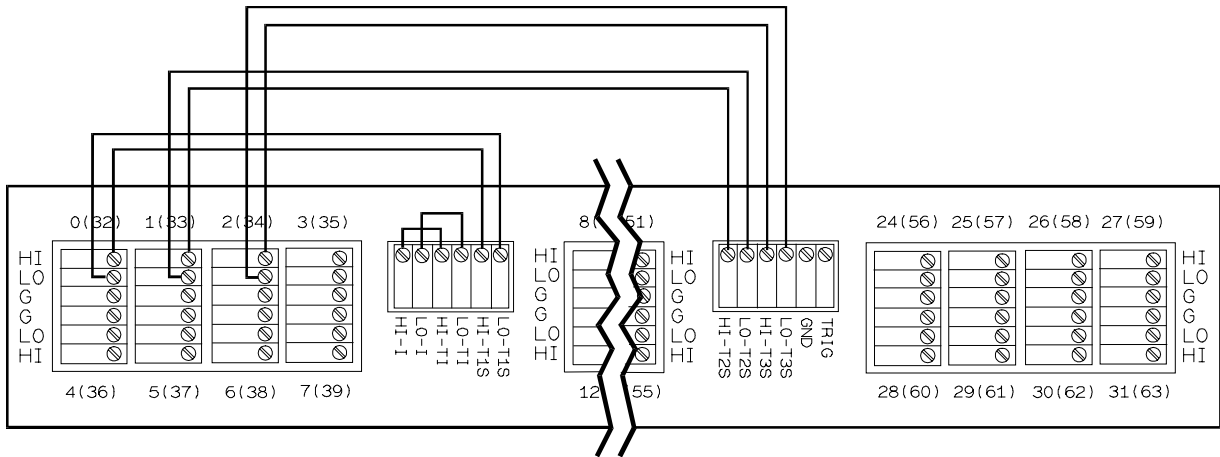

One HP E1586 Terminal Panel  
Measuring Three Thermistors  
on Reference Channels 100, 101, 102

Figure 10. Left, Center, and Right Thermistor Measurements on a Single Panel

**Example Using a Single Terminal Panel:**

```
SENS:REF THER,5000,1,(@100,101,102)
    measures reference temperature measurements on channels 100 to 102
SENS:FUNC:TEMP TC,K,.06,(@103:131)
    defines channels for temperature measurements
ROUT:SEQ:DEF (@100,103:107,101,108:123,102,124:131)
    defines the scan list
```

**Example Using Two Terminal Panels:**

```
SENS:REF THER,5000,1,(@100,101,102,132,133,134)
    measures reference temperature measurements on channels 100 to 102
SENS:FUNC:TEMP TC,K,.06,(@103:131,135:163)
    defines channels for temperature measurements
ROUT:SEQ:DEF (@100,103:107,101,108:123,102,
    124:131,132,135:139,133,140:155,134,156:163)
    defines the scan list
```

Note that each reference channel (100, 101, 102, 132, 133, 134) immediately precedes its associated measurement channels in the scan list.

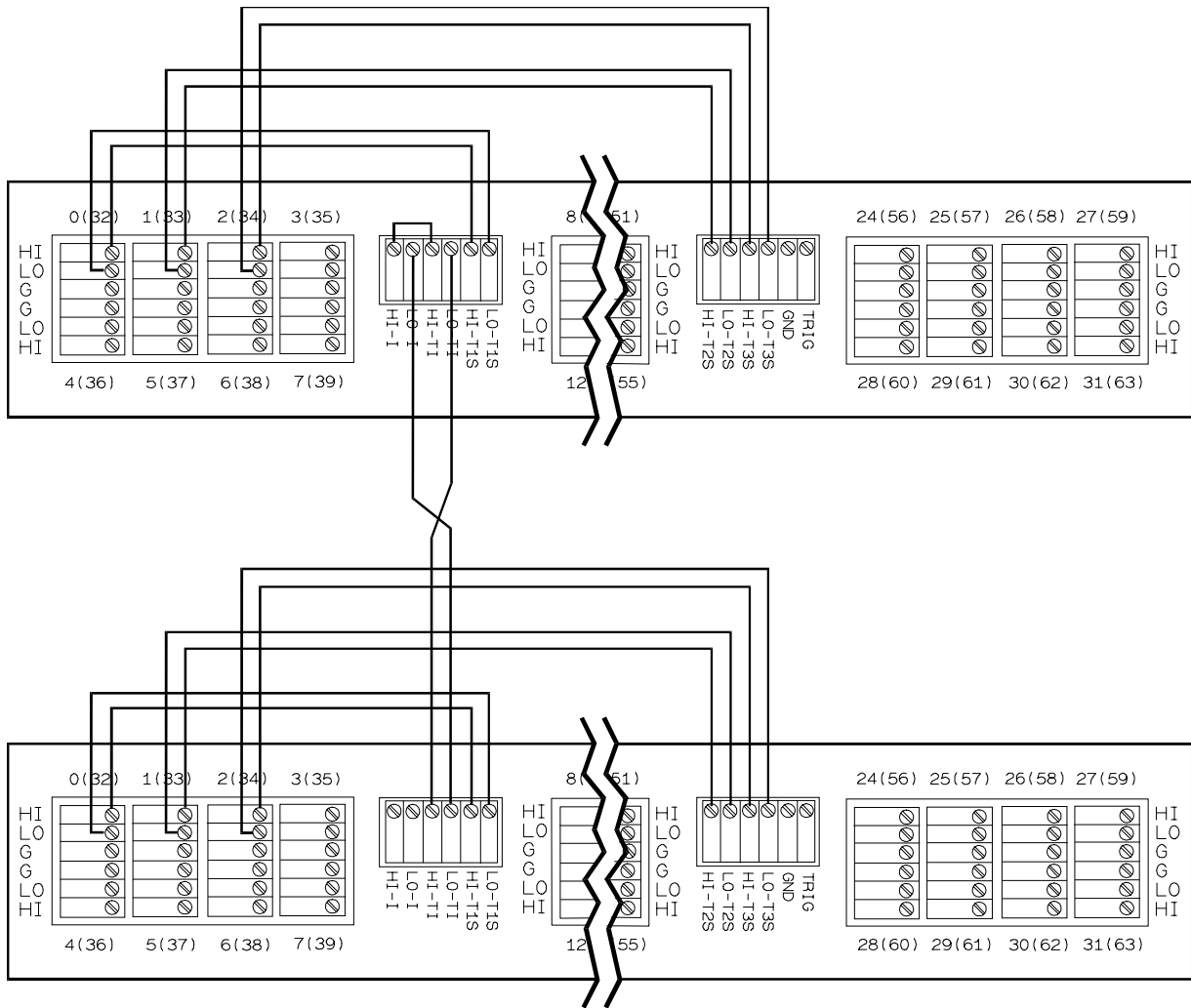

Two HP E1586 Terminal Panels  
 Measuring One Thermistor on Each Panel  
 on Reference Channels 100, 101, 102  
 132, 133, 134

**Figure 11. Left, Center, and Right Thermistor Measurements on Multiple Panels**